



DeNO_x Tank System



Storage Tank Safety System

2nd Containment

1 Solution

0 Leakage

Aboveground double wall storage tank with monitored bottom discharge become a state of the art solution for flammable, chemical and water polluting liquids. This breaking technology allows the first time to open a double wall tank below the liquid level. This method combines the advantages of a single wall tank with the safety aspect of a double wall tank.

Our system , your advantage !

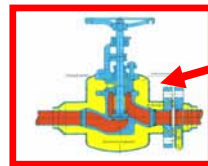
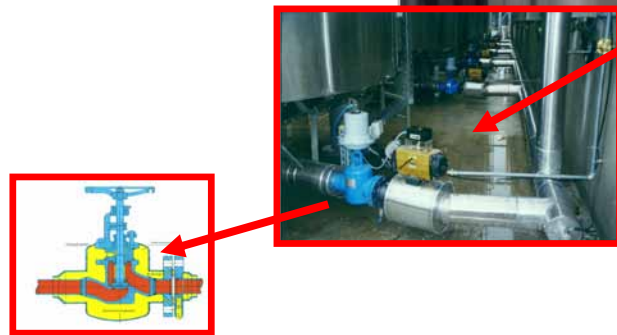

Environment

System overview

Your decision

The two valves after the opening represent the inner and outer wall of the tank. The tightness of both valves in "close" position is continuously monitored with the leak detection device. This is in addition to the leak detection of the secondary containment of the tank itself.

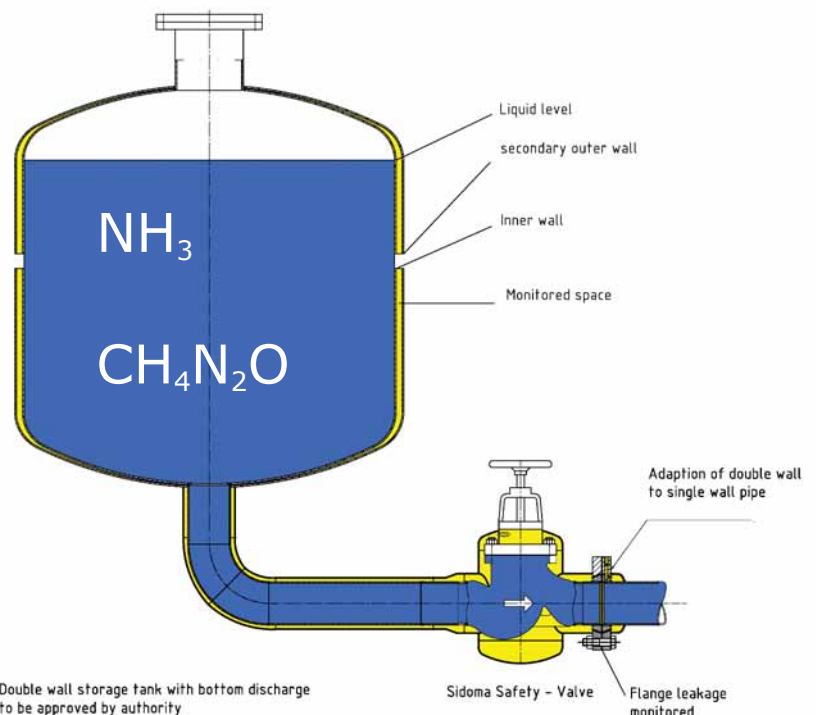

Double wall storage tank with bottom discharge to be approved by authority

System Comparison

1

2

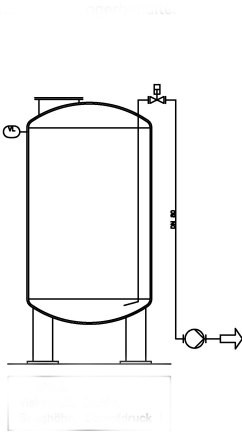
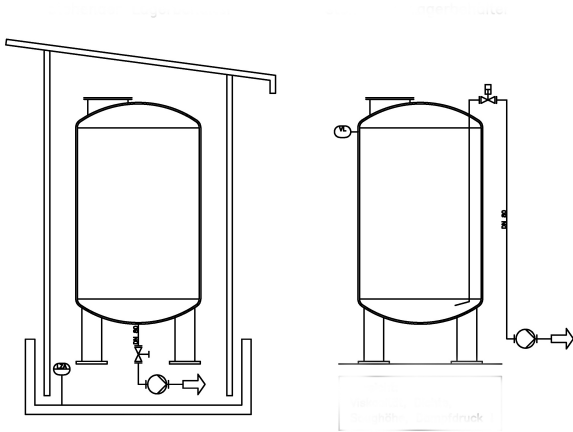

Advantages acc. to concrete containment

- According to concrete containment (1) the double wall system (2) present the best protection of ground water and emissions to the atmosphere
- The monitored containment prevent emissions and malfunctions can be detected and reported without releasing the medium to the atmosphere
- Advanced warning system for possible emissions and leakage
- 20% less costs for new installations in using the double wall system.
- 80% less running costs for the maintenance of the plant (i.e. renovation of concrete containment)
- The flexibility of the tanks are not limited to time and location
- insurance-bonus by implementing this save technology
- Double walled systems represent the best available security for your plant , personell and environment
- In case of malfunction you have an additional opportunity of cooling the system in the containment

Safety, thats for sure !



Solution

Advantages acc. to top load double-wall tanks

- No limitation in height of tanks
- No capsulated pump or
- No self priming pump
- No ascending pipe.
- No cost intensive work on pump in ex area
- No bottom sediment
- No problem with residual cleaning
- Space saving vertical version
- Static pressure guarantees automatic discharge.
- monitoring of medium can be extended to the pipe

2

3

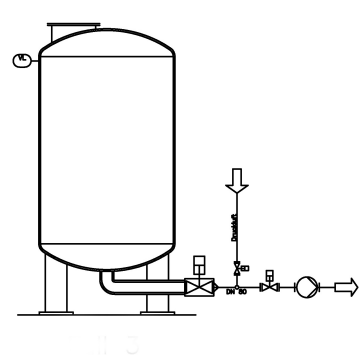
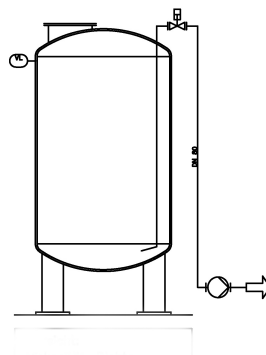

3

Sidoma Safety Systems

Breaking technology !

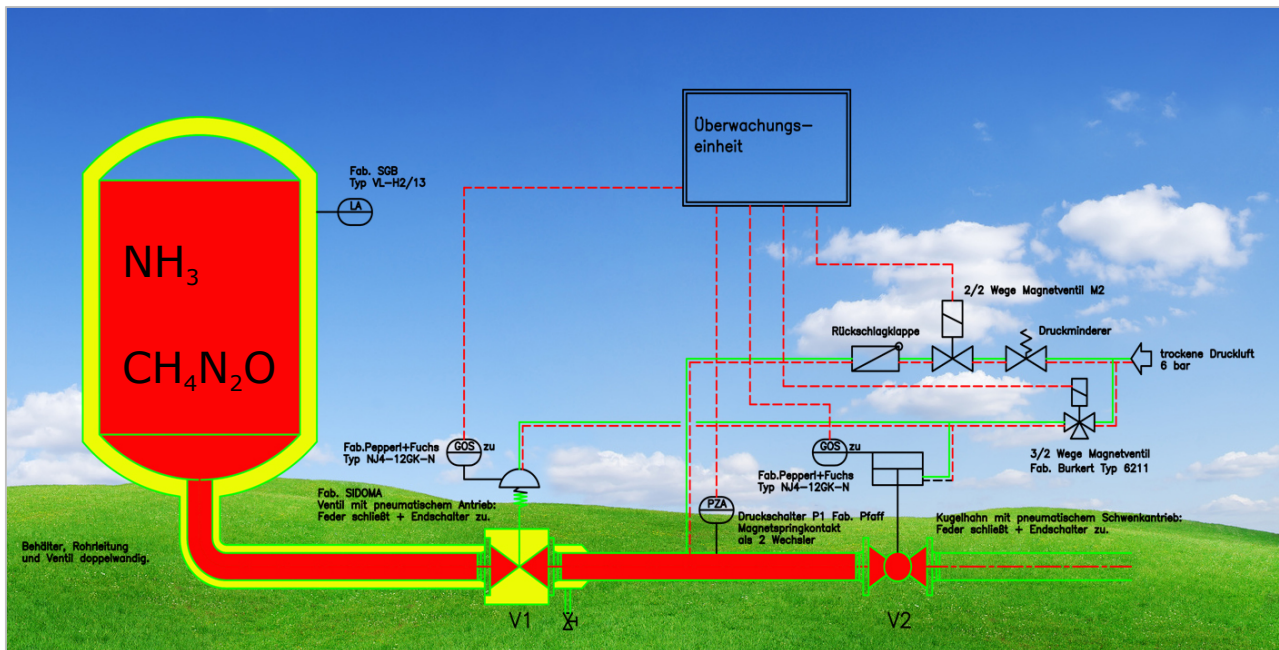

*to be approved by authority

Double wall aboveground steel storage tank with monitored bottom discharge and extended safety circuit.

Green Tech

System description

Two tandem joined valves are pneumatically opened for removal of the liquid out of the tank.

After the removal, the valves are closed by deduction of the auxiliary energy.

The valves are equipped with limit switches and signal "valve close".
The pipe between the valves are overlapped with compressed air $P_1 = 4\text{bar}$ (opening of the solenoid valve M3)

The working pressure is monitored by the pressure switch P_1 .
 $P_A =$ pressure alert = 3,8 bar – 3,9 bar

If new removal is demanded, solenoid valve M3 close and solenoid valve M2 opens. The pressure in the pipe is released to the environment.

If the pressure switch $p_S =$ system pressure reach 0,8 bar ,M2 close and the valves can be opened again.

Legislation

Basic permissions for double walled steel storage tanks with monitored bottom discharge

1. The bottom discharge has to be equipped with two separate simultaneously opening and closing valves. These valves must have a fail save close function. The tightness of the valves in close position has to be monitored by means of a leak detection device.
2. In case of a leak detection alert in the secondary containment both valves at the bottom discharge has to be kept close.
3. The bottom discharge pipe including the body of the first valve has to be double walled as an extension of the monitored secondary containment of the tank. The requirements of basic permissions for leak detection devices are valid for the tank and the extended monitored space.
4. After the opening of the discharging pipe at the bottom of the tank it is forbidden for the extended monitored space to have any removable connections. The maximum length is 2.5 m.
5. The tightness of the bottom discharge has to be guaranteed in case of 30 minutes of fire.

Green technology at its best !

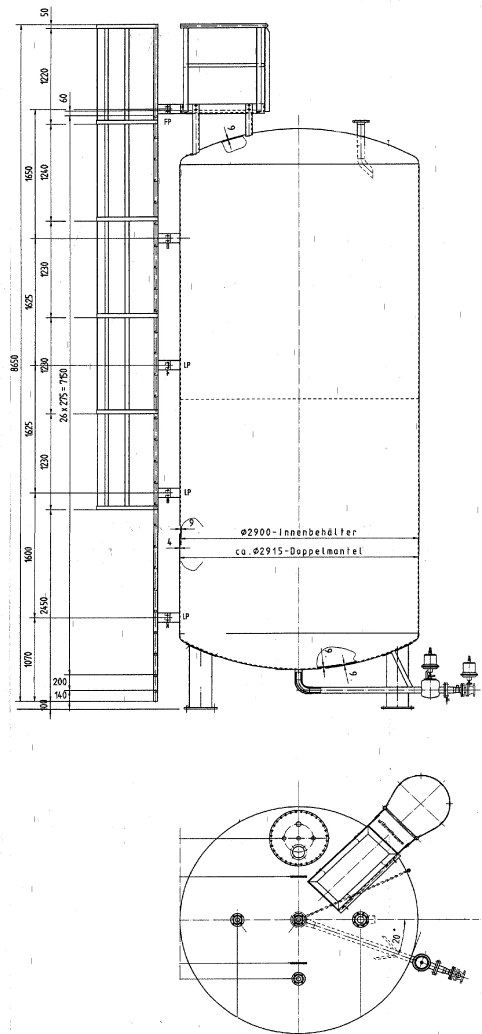

Proven Technology



Exactly your chemistry.



Customer



ArcelorMittal



SIEMENS



Safety system,

That's for sure !



+49 (0)700 74366200

Sidoma® Systeme GmbH

Tel +49(0)69 13020640

info@sidoma.com

Sidoma® Systeme GmbH
Engineering Dep.

Parkstrasse 1
D-65307 Bad Schwalbach / Germany

24/7 Tel / Fax +49 (0)700 